



*Ruggedized ST
Connector*



*Mil ST
Adapter*

About Mil ST

Amphenol Fiber Systems International (AFSI) offers rugged military fiber optic ST connectors for deployable and fixed communication system requirements. AFSI's connectors are designed to provide the best possible optical performance in applications with severe environmental conditions.

Various versions of connectors and adapters are available to meet a broad base of specific needs and system requirements. The M83522 connector is qualified for military applications. This connector features a higher spring force allowing it to meet the shock requirements as specified in MIL-C-83522.

Commercial-Off-The-Shelf (COTS) ST connectors provide the same robustness with a spring force more consistent with commercial ST connectors enabling them to better connect to all other ST connectors and ancillary electronics.

Features and Benefits

- 100% Corrosion proof
- Super and Ultra PC polish capable
- High grade stainless body (17-4 SS) with Zirconia ceramic ferrule, fungus-resistant, self-extinguishing boot
- Superior optical performance in extreme environmental conditions
- MIL-qualified series: high spring force for shock and vibration resistant critical military applications
- MIL-qualified and Navy approved COTS: fungus resistant, self-extinguishing boot with field proven solid ring attachment

Options

- M83522/16- DNX, - DNY
- M83522/17- NX, - NY

Applications

- US Navy shipboard, surface and submarine, mission critical combat and communications systems
- Mobile tactical shelters
- Electronic battlefield networks
- Mobile emergency telecommunications stations
- Deployable outdoor, harsh environment

Materials

- Ferrule: Zirconia
- Body: Stainless steel
- Boot: Fungus resistant, self-extinguishing thermoplastic

How to Order

For more information on how to order or to obtain a price quote on any of our ST Connectors, please call us at 800.472.4225. For international calls please dial 1.214.547.2400 or email us at info@fibersystems.com

About Amphenol Fiber Systems International

Amphenol Fiber Systems International (AFSI) designs, manufactures, markets and supports reliable and innovative fiber optic interconnect solutions that withstand the harsh environments of military, oil & gas, mining and broadcast applications. After more than a decade in business, AFSI continues to uphold its position as a global leader in fiber optic interconnect components and systems such as termini, M28876, MIL-ST, TFOCA and the TFOCA-II[®] connector, which AFSI developed and patented. Altogether, AFSI has delivered millions of fiber optic connectors in more than 22 countries. Whenever there is a need for superior cost-effective fiber optic systems and products that will stand up to demanding operating environments, you can rely on AFSI for engineering know-how, top-quality products and expert technical support.

For more information about AFSI, please visit our web site at www.fibersystems.com

MIL-C-83522 Connector Performance Specifications

Specification

Insertion loss
 Return loss
 Tensile loading
 Mating durability
 Impact
 Dust
 Thermal shock
 Vibration
 Temperature humidity
 Salt spray
 Flammability
 Temperature cycling
 Shock
 Fungus Resistant

Measurement Requirement

< 1.0 dB
 > 30 dB
 > 230 N
 > 500 cycles
 8 times, 1.5 meters
 MIL-STD-202, Method 110
 MIL-STD-1678, Method 4020
 MIL-STD-1344, Method 2005
 DOD-STD-1678, Method 4030
 MIL-STD-1344, Method 1001
 MIL-STD-1344, Method 1012
 -55C to 125C Op, -65C to +200C Non-Op
 MIL-STD-901D, Grade A, Type A, Class I
 MIL-STD-810, Method 508

ST Connector Typical Performance Specifications

Specification

Insertion loss (typical)
 Return loss

Inspection Detail

EIA/TIA-455-34, Method A
 EIA/TIA-455-107

Multimode

-0.2 dB
 -50 dB

Single mode

-0.3dB
 -30 dB

Ruggedized ST Connector

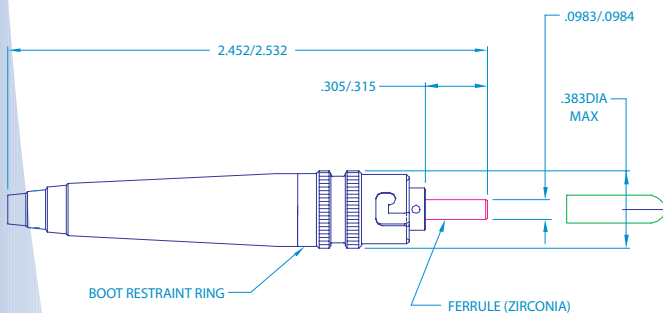

Panel Cut-Out

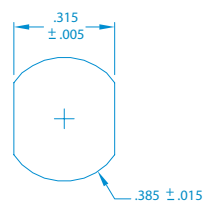

Mil ST Adapter

