



RNJ

Rack and panel cylindrical connectors



MAIN CHARACTERISTICS

- EMI shielding
- Shells are grounding before contact mating
- Lightweight space saving design
- Durability:
500 cycles
- Moisture resistance:
in addition interfacial seal, main joint souffler and rear gasket on the plug are set up for moisture sealing between connectors halves
- Corrosion resistance:
 - Olive drab cadmium over nickel plating on aluminium shell (withstands 500 hours salt spray exposure) or electroless nickel
 - Free cadmium version also available.
- 8 shell sizes from 11 to 25
- Contact protection:
 - 100% scoop-proof. The design prevents bent pins and short circuit during mating.
 - From 1 to 128 contacts in accordance with Mil-C-39029 standard
 - Crimp contacts size 22D, 20, 16, 12, 8, 4, 00.
 - PCB contacts size 22D & 20 (size 16, 12, 8, please consult Amphenol)
 - Wire-wrap contacts size 22D & 20
 - Optical termini (POM series) in accordance with Mil-T-29504 standard
- For environmental applications:
supplied without rear accessories. Design provides serrations on rear threads of shells. Compatible with some M 85049 rear accessories for MIL-C-38999 I connectors. Please consult us.
- Temperature range:
-65°C +175°C
- Insulation resistance > 5000 Mohms at ambient under 500 Vcc

Figure 1 - FEATURES

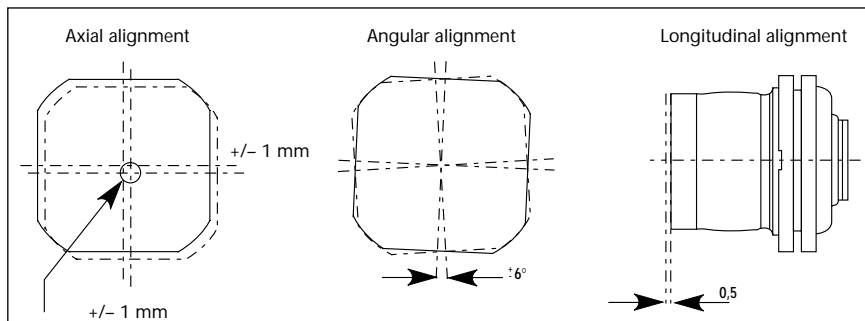

DESCRIPTION

The RNJ series rack and panel connectors are qualified for the requirements of the standard DAT C 5935 x 0005 HE308 21, 25, 26 & 27T models.

They are used to connect electrical and optical devices between a moving unit (rack) and a fixed unit (panel) without any coupling / uncoupling device. This function is ensured by the moving and the fixed unit system.

They allow to integrate the design tolerances between the moving and fixed unit, up to limits indicated figure 1 during the mating of the connectors and up to the rack bottoms the fixed chassis.

These connectors are derived from the LJT series and meet or exceed the MIL-C-38999 Series I requirements.

RNJ: the environmental rack connection

APPLICATIONS

- Military applications & Aeronautic
- Advanced industrial applications

RNJ



Amphenol

Presentation

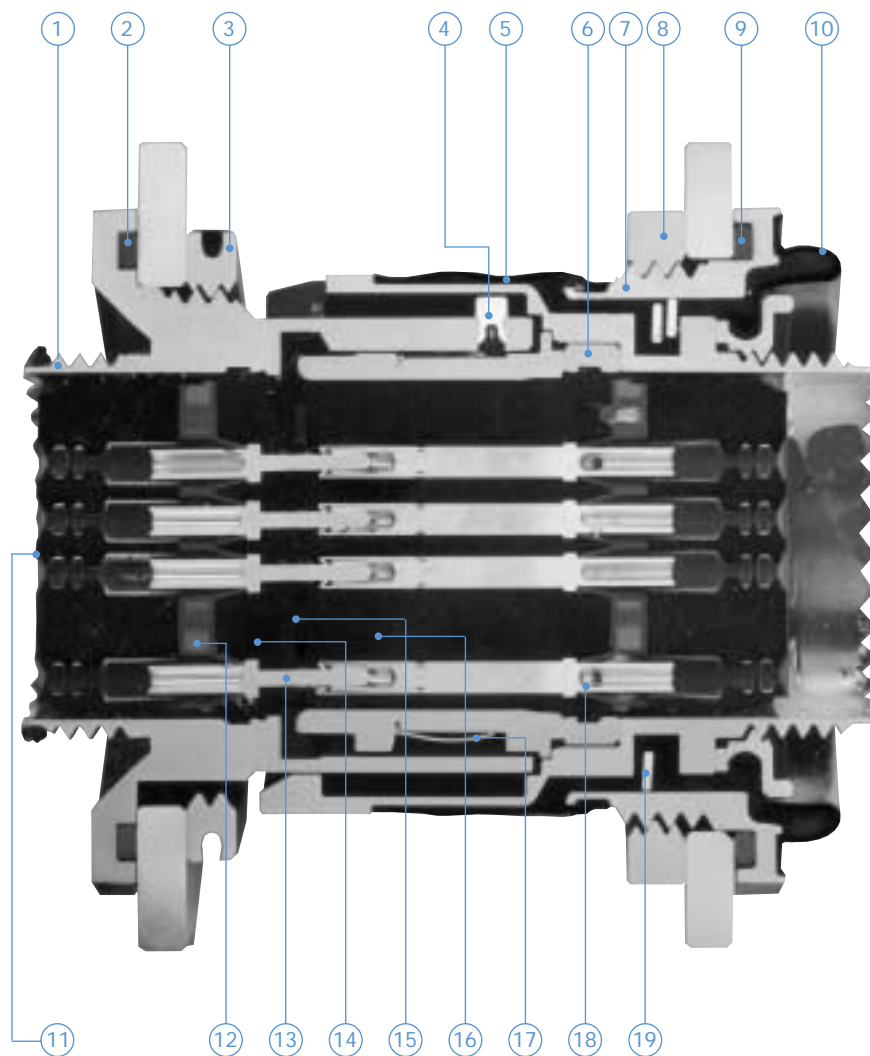

- 1 - Receptacle shell
- 2 - O ring
- 3 - Hexagonal nut
- 4 - Rivet
- 5 - Sealed membrane
- 6 - Free plug shell
- 7 - Fixed plug shell
- 8 - Panel nut (plug)
- 9 - O ring
- 10 - Sealed membrane
- 11 - Grommet
- 12 - Dielectric retention disc
- 13 - Pin contact
- 14 - Male insert
- 15 - Interfacial seal
- 16 - Female insert
- 17 - Grounding fingers
- 18 - Socket contact
- 19 - Spring washers

Environmental characteristics

- Temperature range: -65°C to +175°C
- High temperature endurance 1000 hours
- Humidity 100% R.H.
- Air leakage: 16 cm³/h max under 2 bars differential pressure
- Salt spray:
 - olive drab cadmium 500 h
 - electroless nickel 48 h
- Fluid resistance:
 - MIL - L - 7808
 - MIL - L - 23699
 - MIL - H - 5606
 - Hydraulic fluid (Chevron M2V)
 - MIL - A - 8243
 - MIL - C - 25769 (alkaline solution)
 - MIL - T - 5624 (JP5)
 - Coolanol 25 or equivalent
 - MIL - G - 3056 (Type 1) or equivalent
 - Solvents (a), (b) and (c) MIL - STD 202, method 215
 - Oil OMD 69/110 - 20 W/40 - 0/180
 - Mineral hydraulic fluid H 515 x XH 45
 - Synthetic hydraulic fluid H 542
 - Military fuel, gas-oil F46 and F54

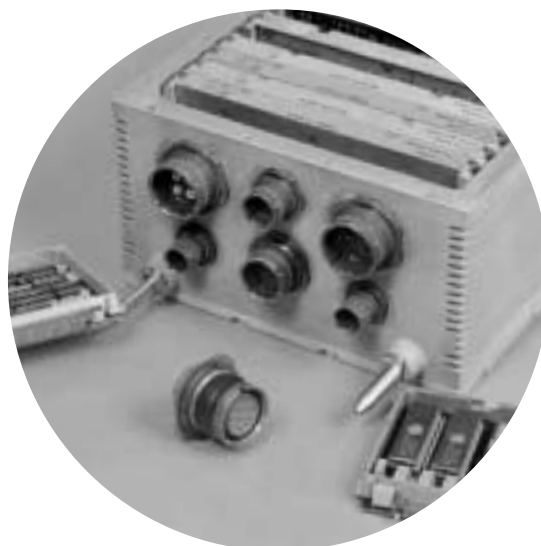

Mechanical characteristics

- Insert retention in the shell: 7 bars
- Contact retention in the insert:

Contact size	22D	20	16	12	8	4	00
Maximum load (N)	45	67	110	110	150	150	150

- Mated and unmated forces

Shell size	Maximum mated force (daN)	Maximum unmated force (daN)
11	20	12
13	30	13
15	35	15
17	50	16
19	55	18
21	65	22
23	80	27
25	102	34

- Durability: 500 cycles
- Sine vibrations 10 . 2000 Hz 30g
- Random vibrations 10 . 2000 Hz 28g
- Shocks: 150g 3 ms 1/3 sinus

Electrical characteristics

- Contact rating: nominal current per contact:

Contact size	22D	20	16	12	8	4	00
Current (A)	5	7.5	13	23	60	100	230

- Contact resistance:

Contact size	22D	20	16	12	8	4	00
Contact resistance (mohms)	8	4.7	2	1.1	0.6	0.26	-

- Insulation resistance: - at ambient > 10⁵ Mohms
- at maximum temperature > 10³ Mohms

- Service rating:

Service (p. 4/5)	Dielectric withstanding voltage (Vrms)								Working voltage	
	At sea level		15000 meters		21000 meters		34000 meters		Vrms	Vdc
	mated	unmated	mated	unmated	mated	unmated	mated	unmated		
M	1300	1300	800	550	800	350	800	200	400	550
I	1800	1800	1000	600	1000	400	1000	200	600	850
II	2300	2300	1000	800	1000	500	1000	200	900	1250

- Dimensions of acceptable contacts and cables:

Contact size	Contact Diameter mm	Crimp barrel		Acceptable cables						
		Diameter mm	Depth mm	Gauge AWG Section mm ²				Outside diameter (mm)		
								min	average	Max
22D	0.76	0.88+/-0.03	3.58	22 0.38	24 0.22	26 0.15	28 0.095	0.76	1.20	1.37
20	1	1.19+/-0.03	5.30	20	22	24		1.02	1.83	2.11
				0.60	0.38	0.22				
16	1.57	1.70+/-0.03	5.30	16	18	20		1.68	2.41	2.77
				1.34	0.93	0.60				
12	2.36	2.54+/-0.06	5.30	12	14			2.46	3.20	3.61
				3.30	1.94					
8	3.60	4.6 +0.05-0	10	8				4.50		5.8
				8.98 Max acceptable: 10mm ²						
4	5.75	7.4+/-0.05	12	21.10				7.73	8.08	8.43
00	12	14.6+0.05	21	100				13.3	—	14.7

Insert arrangements

Front face view of male insert

The major keyway is shown in the «normal» position

Contact size	22D	20	16	12	8	4	00
Caption							

- ① : LJT & MIL insert arrangement reference
- ② : Number of contacts
- ③ : Contact sizes
- ④ : Service (See page 3)

SIZE 11 SHELL

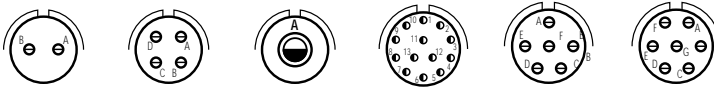

①	11-2	11-4	11-12	11-35	11-98	11-99
②	2	4	1	13	6	7
③	20	20	12	22D	20	20
④	I	I	II	M	I	I

SIZE 13 SHELL

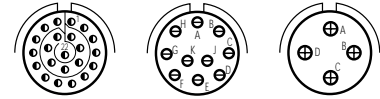

	13-35	13-98	13-4
②	22	10	4
③	22D	230	16
④	M	I	I

SIZE 15 SHELL

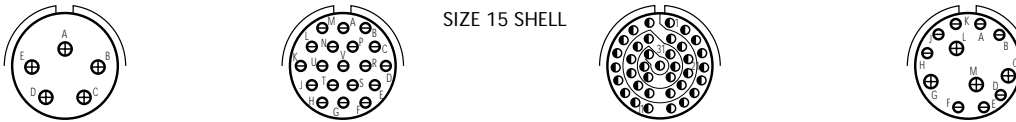

①	15-5	15-19	15-35	15-97
②	5	19	37	4 + 8
③	16	20	22D	16 20
④	II	I	M	I

SIZE 17 SHELL

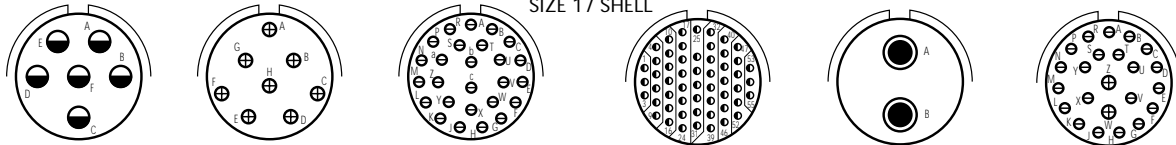

①	17-6	17-8	17-26	17-35	17-75	17-99
②	6	8	26	55	2	2 + 21
③	12	16	20	22 D	8 TWINAX	16 20
④	I	II	I	M	I	I

SIZE 19 SHELL

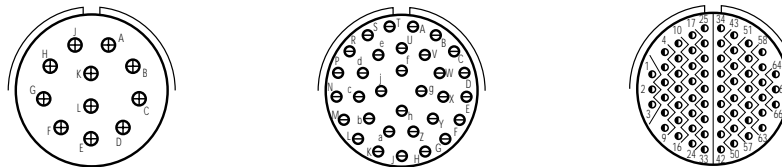

①	19-11	19-32	19-35
②	11	32	66
③	16	20	22 D
④	II	I	M

SIZE 21 SHELL

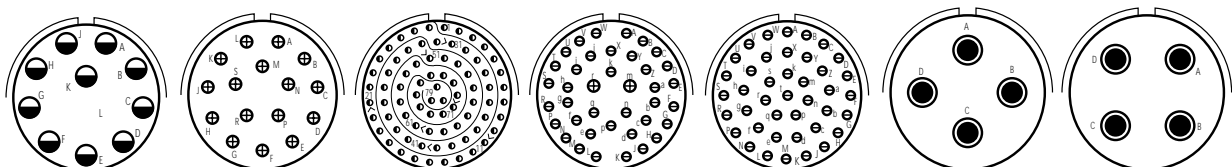

①	21-11	21-16	21-35	21-39	21-41	21-48	21-75
②	11	16	79	2 + 37	41	4	4
③	12	16	22D	16 20	I	8 Puissance	8 Coax
④	I	II	I	I	20	M	I

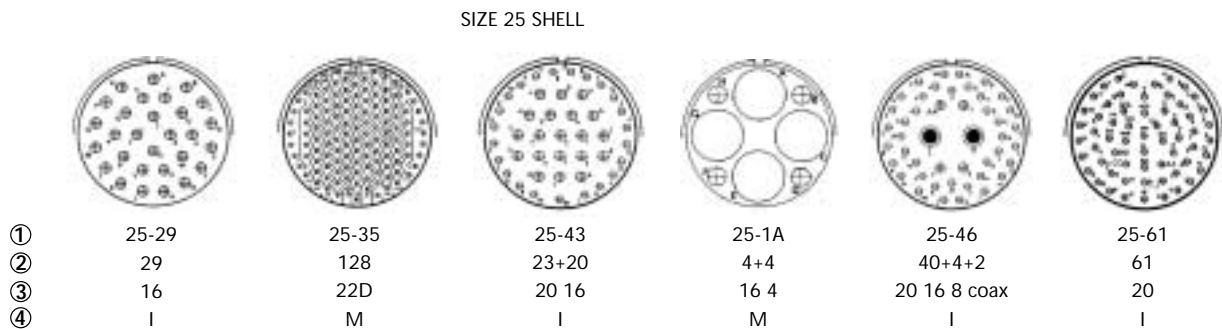
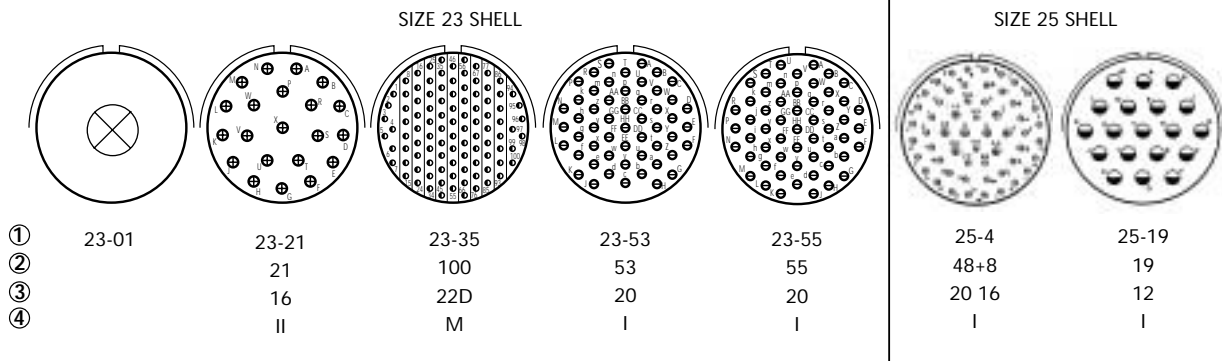

Insert arrangements	Service (see page 3)	Number of contacts	Number of contacts by size							
			22D	20	16 POWER	12 POWER COAX	8 COAX TRIAXIAL	8 POWER	4 POWER	00 POWER
LJT & MIL										
11-2	I	2		2						
11-4	I	4		4						
11-12	II	1				1				
11-35	M	13	13							
11-98	I	6		6						
11-99	I	7		7						
13-4	I	4			4					
13-35	M	22	22							
13-98	I	10		10						
15-5	II	5			5					
15-19	I	19		19						
15-35	M	37	37							
15-97	I	12		8	4					
17-6	I	6				6				
17-8	II	8			8					
17-26	I	26		26						
17-35	M	55	55							
17-75	I	2					2			
17-99	I	23		21	2					
19-11	II	11			11					
19-32	I	32		32						
19-35	M	66	66							
21-11	I	11				11				
21-16	II	16			16					
21-35	M	79	79							
21-39	I	39		37	2					
21-41	I	41		41						
21-48	I	4						4		
21-75	I	4					4			
23-01		1								1
23-21	II	21			21					
23-35	M	100	100							
23-53	I	53		53						
23-55	I	55		55						
25-4	I	56		48	8					
25-19	I	19				19				
25-29	I	29			29					
25-35	M	128	128							
25-43	I	43		23	20					
25-1A	M	8			4			4		
25-46	I	46		40	4		2			
25-61	I	61		61						

Please consult us for other insert arrangements.

Overall dimensions

Receptacle *

Jam nut receptacle for both crimp and PCB contacts

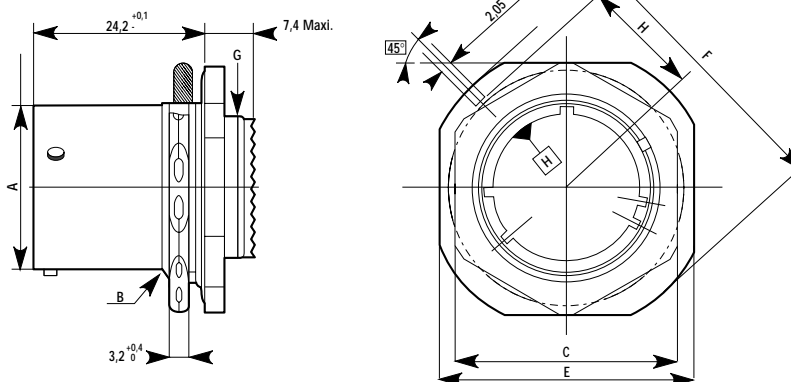

(Dimensions in mm)

Shell size	Diameter A Max (mm)	Thread B Class 2A (inches)	C Max. (mm)	E +/-0.25 (mm)	Diameter F +/-0.41 (mm)	Thread G Class 2A UNEF	H +0 -0.25 (mm)	Mass with contacts (average)	
								Male (g)	Female (g)
11	17.78	0.8125-20 UNEF	25.80	31.75	35.20	0.5625-24	15.33	16	19.50
13	21.59	1.0000-20 UNEF	30	34.92	38.38	0.6875-24	16.92	22.50	28
15	24.77	1.1250-18 UNEF	33	38.10	41.55	0.8125-20	18.51	28	37
17	27.94	1.2500-18 UNEF	37	41.27	44.73	0.9375-20	20.10	33	46.50
19	30.66	1.3750-18 UNEF	40	46.02	49.51	1.0625-18	22.67	41.50	58.50
21	33.83	1.5000-18 UNEF	43	49.23	52.65	1.1875-18	24.26	50.50	71
23	37.01	1.6250-18 UNEF	46	52.37	55.86	1.3125-18	25.84	55.50	82.50
25	40.18	1.7500-18 UNS	51.20	55.54	59	1.4375-18	27.83	63	98

Plug *

With rear accessory possibility

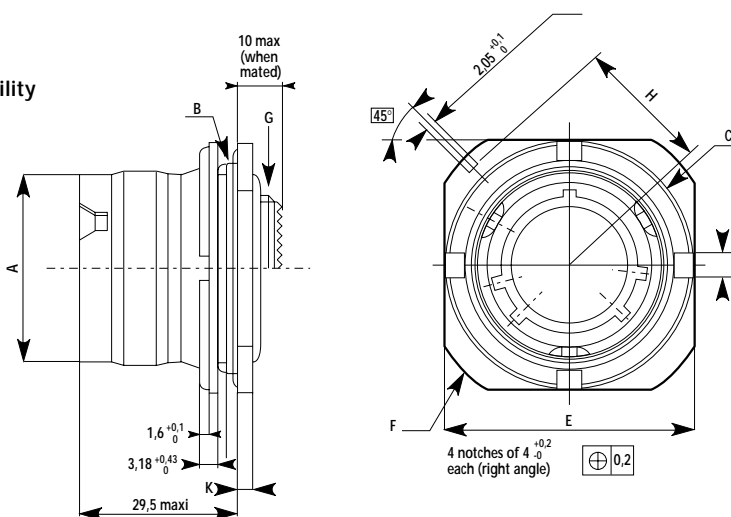

Without rear accessory possibility

(Dimensions in mm)

Shell size	Diameter A +0.03 -0.13 (mm)	Thread B Class 2A (inches)	C Max. (mm)	E +/-0.41 (mm)	Diameter F Max. (mm)	Thread G Class 2A UNEF	H +0 / -0.2 (mm)	K +0.28 / -0.25 (mm)	Mass with contacts (average)	
									Male (g)	Female (g)
11	23	1.0000-20 UNEF	32.10	32.16	38.10	0.5625-24	16.92	2.77	24	28
13	26.80	1.1250-18 UNEF	35.25	36.34	41.27	0.6875-24	18.51	2.77	28	34
15	30	1.2500-18 UNEF	38.40	38.51	44.45	0.8125-20	20.10	2.77	32	41
17	33.22	1.3750-18 UNEF	41.60	41.69	49.23	0.9375-20	22.67	2.77	38	51
19	36.20	1.5000-18 UNEF	46.30	46.43	52.37	1.0625-18	24.26	3.56	48	65
21	39.40	1.6250-18 UNEF	49.60	49.64	55.58	1.1875-18	25.84	3.56	67	87
23	42.60	1.7500-18 UNS	52.70	52.78	58.72	1.3125-18	27.43	3.56	83	111
25	45.68	1.8750-16 UN	53.90	54.04	59.10	1.4375-18	27.58	3.56	104	125

*: Only RNJ specific dimensions are mentioned in these figures.
All dimensions which are not mentioned meet the Mil-C-38999 Series I Standard.

Connector mounting

Generalities

- The dimension of $36^{+0}_{-0.5}$ between flange is imperative to secure the technical performances at the mating position.
- A guiding system has to make the right position of the rack independently of the connectors.
- No mechanical stress must be applied to the rear of the plug by the wires.
- To mount an accessory on the plug, it is necessary to use a holding support to stop the internal set of the plug.

Mated connectors

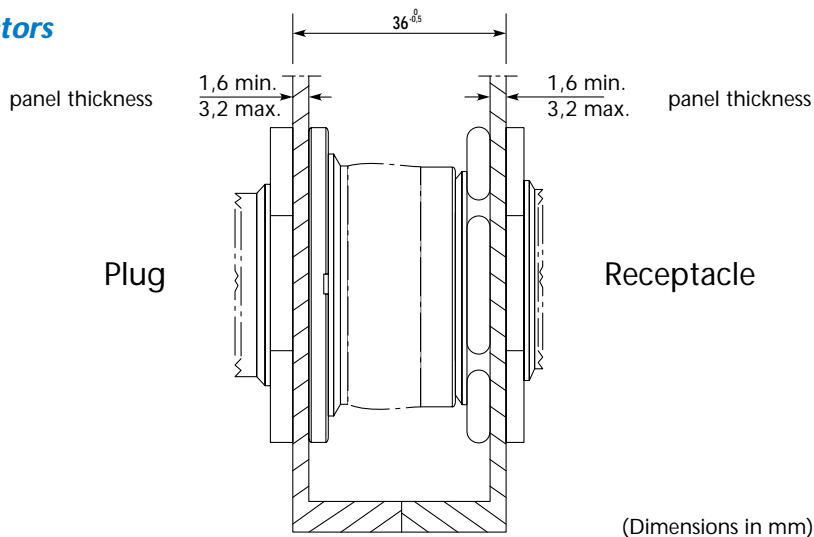

Panel drilling and recommended hexagonal nut coupling torque

Plug	Shell size		K (min)	W (mm)	Diam. X (mm) +0.1/-0	Nut coupling torque (min)
	Plug	Receptacle				
-	11			11.69	20.88	4.5/5.7
11	13		32.60	12.81	25.58	6.2/6.8
13	15		36	13.94	28.80	7.9/8.5
15	17		39.60	15.06	31.98	9/9.6
17	19		43.30	16.88	35.15	10.2/10.7
19	21		47	18.00	38.28	11.3/12.4
21	23		50.60	19.12	41.50	12.4/13.6
23	25		54.20	20.24	44.68	13.6/14.7
25	—		59.70	20.30	48.08	14.7/15.8

Hole

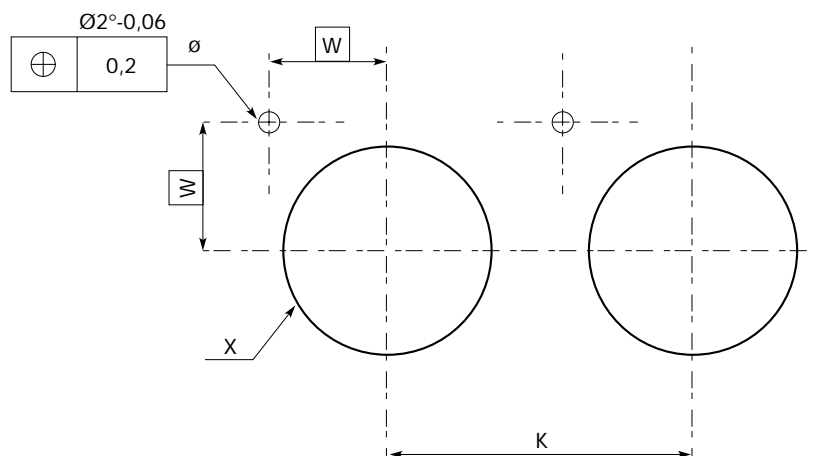

Rear accessories coupling torque

The following values must be respected.
Before to apply this coupling torque, locking glue has to be put on the rear thread of the connector.

Shell size	11	13	15	17	19	21	23	25
Coupling torque (Nm)	8 ± 0.4	11 ± 0.5	11 ± 0.5	14 ± 0.7	14 ± 0.7	17 ± 0.8	17 ± 0.8	20 ± 0.1

Proprietary P/N

Series	RNJ	26	T	11	35	P	014		LC
Shell type	26: Plug with accessory possibility 27: Jam nut receptacle 46: Plug without accessory possibility <i>(For plug and receptacle with square flange, please consult us)</i>								
Service class and contact type	T: Environnemental crimp applications, # 22D/20/16/12/8/4/00 CI: Environnemental solder applications on PCB (receptacle only), # 22D/20/16 <i>(for sizes 12 and 8, please consult us)</i> DW: Environnemental wire-wrapping applications (receptacle only), # 22D/20								
Shell size	11/13/15/17/19/21/23/25								
Insert arrangement	<i>See on pages 4/5</i>								
Contact style	P: Pin S: Socket								
Shell finish	014: Olive drab cadmium 023: Electroless nickel								
Polarization	Normal position only. No letter required								
Contacts	Blank: Connector delivered with contacts LC: Connector delivered less contact (no marking on the connector)								

For deviation (Fxxx), please consult us

Do not hesitate to contact us for further information

Amphenol

Amphenol Socapex

Mil/Aero & Industrial Business Unit

948, Promenade de l'Arve - BP 29

F - 74311 Thyez Cedex

Tel.: +33 (0) 4 50 89 28 00 - Fax: +33 (0) 4 50 96 19 41

<http://www.amphenol.com>

Sales office

Tel.: +33 (0) 1 49 05 30 00 - Fax: +33 (0) 1 49 05 30 43