



TFOCA Receptacle

TFOCA Plug



About TFOCA

In 1999, Amphenol Fiber Systems International (AFSI) designed the TFOCA connector series as a direct replacement for the connector portion of the US Army's legacy TFOCA (Tactical Fiber Optic Cable Assembly) equipment. This connector series has become known simply as "TFOCA." The AFSI TFOCA series has been formally approved by CECOM (US Army Communications Electronics Command Fort Monmouth, NJ) and meets the performance criteria as specified in MIL-C-83526. In addition, AFSI is fully qualified and formally approved by CECOM to fabricate cable assemblies using the AFSI TFOCA connector. These assemblies have been tested in accordance with MIL-C-49292.

The TFOCA connector is a hermaphroditic design utilized for tactical deployable communications systems. This genderless characteristic allows for concatenations of cable assemblies without regard for connector interface compatibility.

The ruggedized connector and housing will withstand the repeated handling and mating cycles typically required for rapid fiber optic cable deployment and retrieval in a tactical environment.

Kevlar® is a registered trade mark of E.I. du Pont de Nemours and Company. Quickloc™ is a trademark of Amphenol Fiber Systems International.

Maintainability

All Amphenol Fiber Systems International TFOCA connectors have a removable end cap to allow field level repair and cleaning. Removing the cap allows direct access to the alignment sleeve and termini for thorough cleaning and periodic maintenance.

Features

- Hermaphroditic design ideal for deployable conditions.
- Replacement for US Army and US Marine Corps legacy TFOCA (AT&T)
- Hermaphroditic design
- Multimode
- Field maintainable and repairable
- Biconic termini

Benefits

The TFOCA's unique design and environmentally protected construction provide protection from high compressive and tensile loads. In addition, seals at every interface ensure outstanding resistance to moisture penetration. The cable termination is designed to firmly anchor the cable Kevlar® strength members to the connector housing without special tooling. The AFSI TFOCA connectors can be terminated and repaired in the field using existing US Army equipment or the AFSI TFOCA Termination Kit (P/N KTBK7000).

Applications

- Military tactical deployable communication systems
- Legacy US Army Systems
- Legacy US Marine Corps Systems

How to Order

For more information on how to order or to obtain a price quote on any of our TFOCA Products, please call us at 800.472.4225. For international calls please dial 214.547.2400 or email us at info@fibersystems.com

TFOCA Specifications

Specification	Measurement/Detail
Number of Channels	2 Channels
Optical Loss (Typical) (MM)	0.6 dB
Field Maintainable	Yes. Only requires common tools (screwdriver). No special tools required
Fiber Type	50/125 Radiation hard fiber available (phosphorus free)
Insertion Loss	50/125 Multimode fiber -0.6db typical
Operating Temperature	-10°C to +75oC
Mud	Per MIL-C-83526 /12 and /13
Shock	EIA/TIA-455-14, Condition A
Vibration	MIL-STD-1344, Method 2005.1
Cable Retention	400 lbs minimum per EIA/TIA-455-6 (applies to plug)
Twist	1000 cycles per EIA/TIA-455-36
Cable Seal Flexing	100 cycles per MIL-STD-1344, Method 2017, Procedure I
Mating Durability	2000 cycles per EIA/TIA-455-21
Water Pressure	Per MIL-C-83526 /12 /13 Requirements
Ice Crush/Freezing Water Immersion	Per MIL-C-83526 /12 /13 Requirements
Impact	Per EIA/TIA-455-2
Crush Resistance	450 lbs minimum per EIA/TIA-455-26
Flammability	MIL-STD-1344, Method 1012

TFOCA Plug

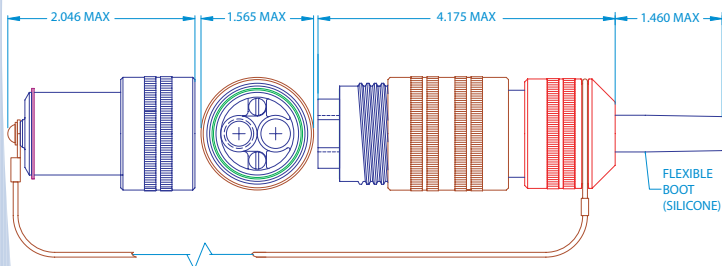

TFOCA Panel Cut Out

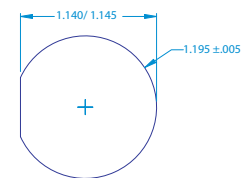

TFOCA Receptacle

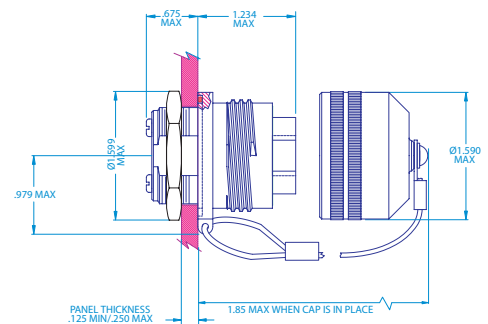

About Amphenol Fiber Systems International

Amphenol Fiber Systems International (AFSI) designs, manufactures, markets, and supports reliable and innovative fiber optic interconnect solutions that withstand the harsh environments of military, oil & gas, mining and broadcast applications. After more than a decade in business, AFSI continues to uphold its position as a global leader in fiber optic interconnect components and systems such as termini, M28876, MIL-ST, TFOCA, and the TFOCA-II® connector, which AFSI developed and patented. Altogether, AFSI has distributed millions of fiber optic connectors in more than 22 countries. Whenever there is a need for superior cost-effective fiber optic systems and products that will stand up to demanding operating environments, you can rely on AFSI for engineering know-how, top-quality products and expert technical support.

For more information about AFSI, please visit our web site at www.fibersystems.com.

Publication: AFSI-TFOCA-F-03.21.05 Specifications subject to change without notice.
www.fibersystems.com - info@fibersystems.com

© Copyright Amphenol Amphenol Fiber Systems International. All rights reserved.

Corporate Headquarters

Amphenol Fiber Systems International, Inc.
 1300 Central Expressway North, Suite 100
 Allen, TX 75013
 Phone: 214.547.2400 - 800.472.4225
 Fax: 214.547.9344