

Issue No.	Eng. Ref. No.	REVISIONS	Date	App. By
12	--	CONSTANT FORCE SPRING IS ADDED	09/11/16	SPK
13	B302	90° FORM- FIGURE & NOTE ADDED	16/07/18	SPK

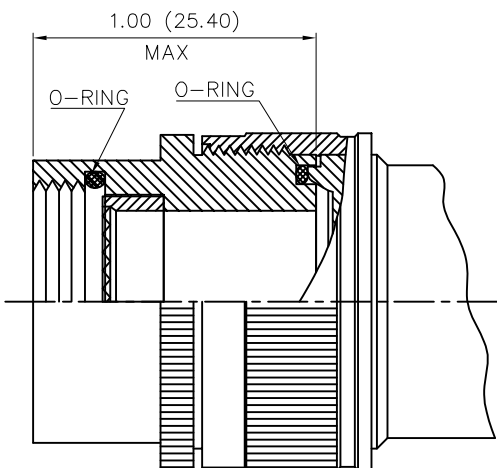

PART NUMBERING SYSTEM :-

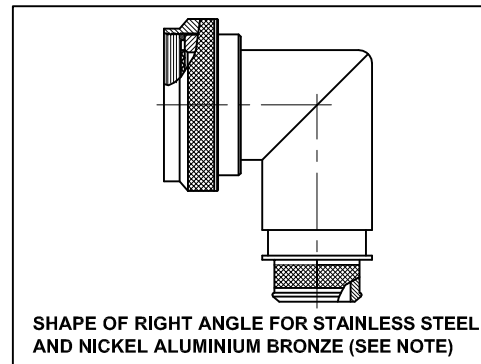
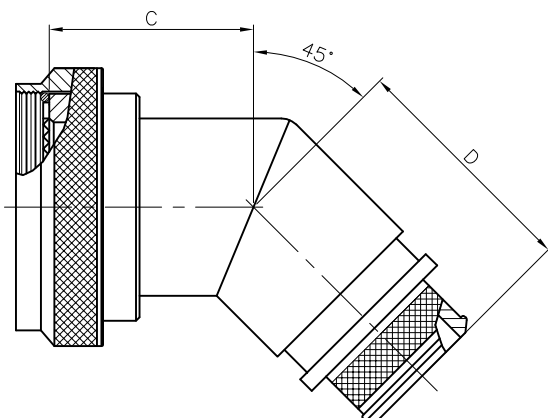
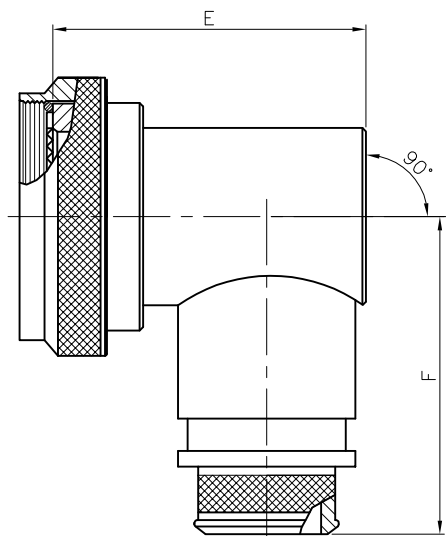
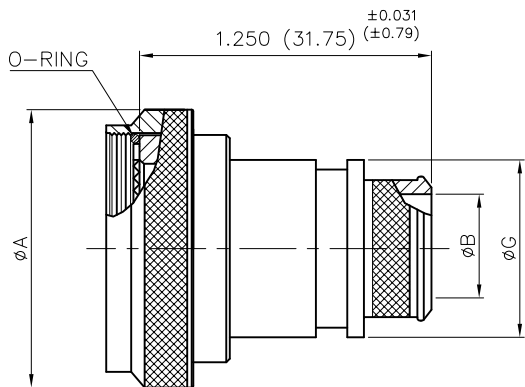
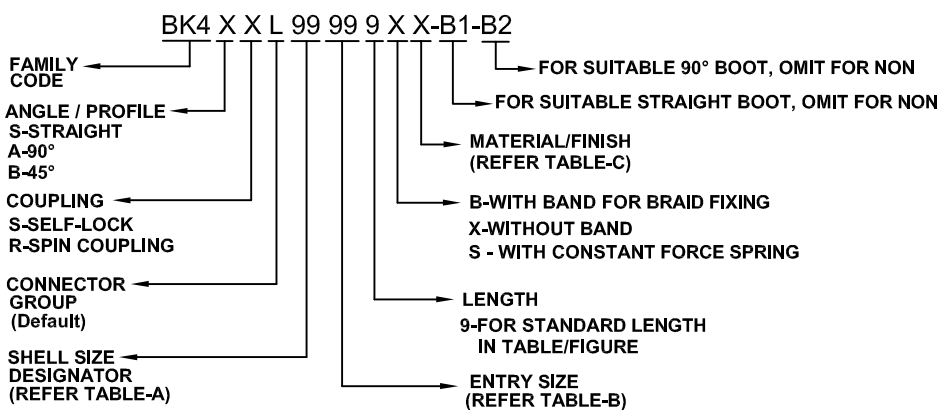

STYLE-2 : MODIFICATION

<p>Amphenol AIPL</p>		<p>TITLE BAND LOCK ADAPTER (BK4) FOR CONNECTORS MIL-C-38999 SERIES III & IV</p>			
		<p>All Dimensions are in INCHES(MM)</p>		<p>STANDARD</p>	
<p>Name</p>	<p>Date</p>	<p>Dwg. Size</p> <p>A4</p>	<p>Dwg.No.</p> <p>PSTDBS237</p>		<p>Sheet 1 OF 2</p>
<p>Drawn by <i>T.M.A.P</i></p>	<p>16/03/09</p>		<p>Doc. No.: QF-DEV-76</p>		
<p>Checked by KSC</p>	<p>16/07/18</p>		<p>REV. NO. : 02</p>		
<p>App.by SPK</p>	<p>16/07/18</p>				

Issue No.	Eng. Ref. No.	REVISIONS	Date	App. By
12	--	CONSTANT FORCE SPRING IS ADDED	09/11/16	SPK
13	B302	90° FORM- FIGURE & NOTE ADDED	16/07/18	SPK

☞ **TABLE-A:-**

SHELL SIZE DESIGNATOR	MAX. ENTRY SIZE (Normal Style)	CONNECTOR SHELL SIZE/CODE	ØA MAX.		C MAX.		D MAX.		F MAX.		E MAX.	
			INCH	MM	INCH	MM	INCH	MM	INCH	MM	INCH	MM
08	04	09/A	0.86	21.82	0.519	13.20	1.150	29.21	1.279	32.51	0.839	21.33
10	06	11/B	0.99	25.04	0.540	13.72	1.170	29.72	1.339	34.03	0.970	24.64
12	08	13/C	1.16	29.36	0.570	14.48	1.200	30.50	1.409	35.81	1.090	27.69
14	10	15/D	1.28	32.54	0.590	14.99	1.230	31.25	1.469	37.33	1.219	30.98
16	12	17/E	1.41	35.71	0.620	15.75	1.250	31.75	1.529	38.86	1.339	34.03
18	14	19/F	1.52	38.51	0.629	16.00	1.259	32.00	1.589	40.38	1.409	35.81
20	15	21/G	1.64	41.68	0.659	16.76	1.289	32.76	1.659	42.16	1.529	38.86
22	17	23/H	1.77	44.86	0.681	17.30	1.320	33.53	1.719	43.68	1.659	42.16
24	20	25/J	1.89	48.03	0.708	18.00	1.339	34.03	1.779	45.21	1.779	45.21

☞ **TABLE-B:-**

ENTRY SIZE	ØB +0.010-0.020 (+0.25-0.50)		ØG MAX	
	INCH	MM	INCH	MM
02	0.124	3.17	0.208	9.80
03	0.187	4.75	0.528	13.40
04	0.250	6.35	0.547	13.90
05	0.311	7.92	0.591	15.00
06	0.374	9.52	0.657	16.70
07	0.437	11.12	0.717	18.20
08	0.500	12.70	0.780	19.80
09	0.562	14.30	0.843	21.40
10	0.625	15.88	0.906	23.00
11	0.688	17.50	0.969	24.60
12	0.750	19.05	1.031	26.20
13	0.812	20.65	1.094	27.80
14	0.875	22.23	1.157	29.40
15	0.938	23.83	1.220	31.00
16	1.000	25.40	1.283	32.60
17	1.082	27.50	1.346	34.20
18	1.125	28.58	1.409	35.80
19	1.208	30.70	1.472	37.40
20	1.250	31.75	1.535	39.00
21	1.333	33.88	1.598	40.60
22	1.374	34.92	1.661	42.20
23	1.440	36.58	1.744	44.29
24	1.500	38.10	1.787	45.40

☞ **TABLE-C:-**

Code	Material/Finish
N	Aluminium Alloy/Electroless Nickel
W	Aluminium Alloy/Cadmium Olive drab over Electroless Nickel.
Y	Aluminium Alloy/Zinc-cobalt dark olive drab over Electroless Nickel.
TN	Aluminium Alloy/Nickel Teflon
ZN	Aluminium Alloy/Zinc Nickel
S	Stainless Steel/Passivate
K	Nickle Aluminium Bronze/Shot blast
P	Aluminium Alloy/Cadmium Olive drab over Electroless Nickel. (SELECTIVE PLATING)

☞ **MATERIAL:-**

- ⇨ Aluminium alloy as per ASTM B211 / B85
- ⇨ Corrosion resistant steel as per AMS-QQ-S-763

☞ **NOTE:-**

- ⇨ When Maximum Cable Entry Exceed's Connector Shell Diameter, Style-2 will be Supplied.
- ⇨ In Style-2 For Single Piece Construction Add (-14) Suffix in the part No.
- ⇨ For more Cable Entry and Length options please refer PSTDBS510.
- ⇨ E and F Dimensions are increased by 4.0 when the Parts are Fabricated from Stainless Steel and Nickel Aluminium Bronze

Amphenol
AIPL

TITLE **BAND LOCK ADAPTER (BK4)**
FOR CONNECTORS MIL-C-38999 SERIES III & IV

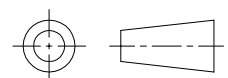

All Dimensions are in
INCHES(MM)

STANDARD

	Name	Date
Drawn by	T.M.A.P	16/03/09
Checked by	KSC	16/07/18
App.by	SPK	16/07/18

Dwg. Size
A4

Dwg.No.

PSTDBS237

Doc. No.: QF-DEV-76
REV. NO. : 02

Sheet 2 OF 2